

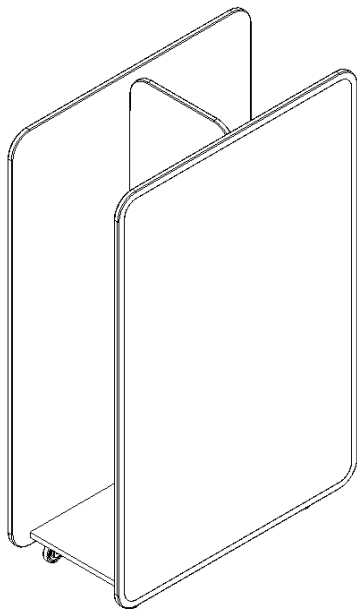

Nimbus Mobile

ASSEMBLY INSTRUCTIONS



WARNING
Risk of injury to installers and users
Read the entire assembly directions before
beginning assembly.

Hardware & Tools Required

Tools:
5/32" Allen Key (Not included)

Hardware:
¼"-20 x 5/8" Button Head Hex Screw – 16
¼" lock washer – 16
Swivel Caster – 2
Ridged Caster – 2

Nimbus Mobile

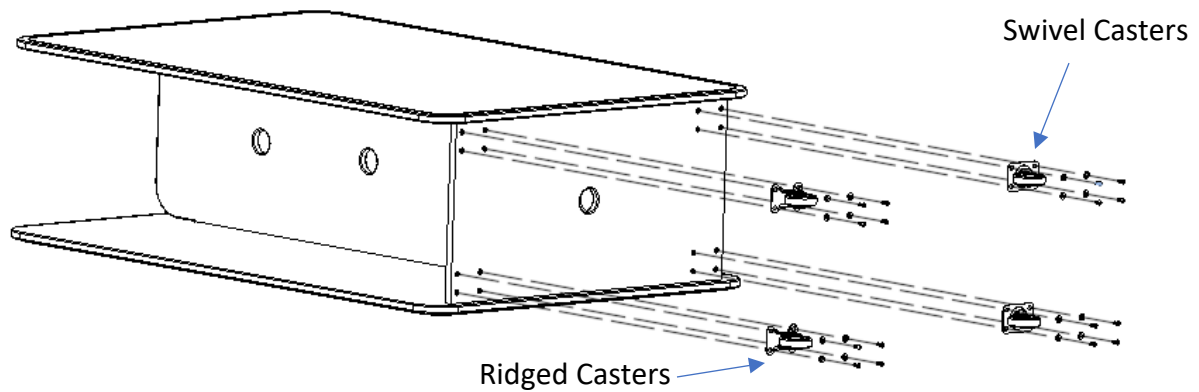

Assembly

1. Gently place Nimbus Mobile on onside as shown above. (2 people required)
2. Use a 5/32" Allen Key to attach the 1/4-20 x 5/8" Screw with locker washer (4 each per caster) Attach Ridged casters to the open front section of the cart.
3. Repeat step 2. To attach the Swivel casters to the back section of the cart.
4. Carefully return cart to upright position.

Your Nimbus Mobile is now ready for all your storage needs. Enjoy!

