

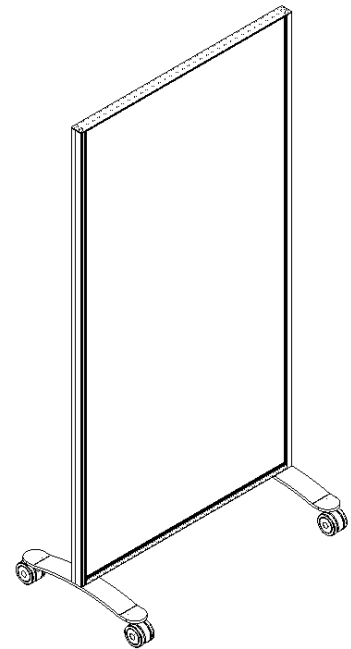

X2 Mobile Board

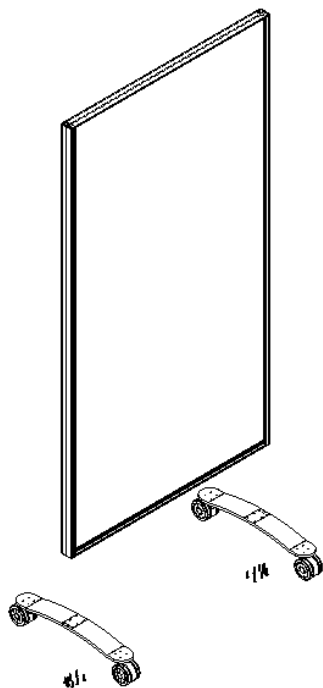

ASSEMBLY INSTRUCTIONS



Package Contents:

1. X2 Framed Board
2. Base with casters (x2)
3. #8 x 1" Screws (x8)
4. #8 x 2 1/2" Screws (x4)
5. 5/16"-18 x 1 1/4" PH Screws (x2)

WARNING
Risk of injury to installers and users
Read the entire assembly directions before
beginning assembly.

X2 Mobile Board

ASSEMBLY of Casters to base

1. Lay base feet out with the stems up and hole positioned as shown.
2. Snap Casters onto stems making sure the locking and non-locking casters are on the same side.

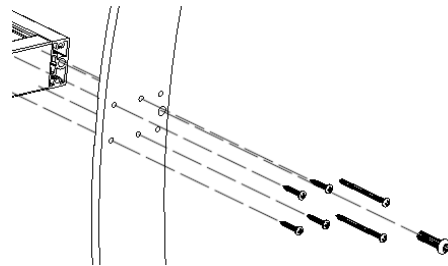
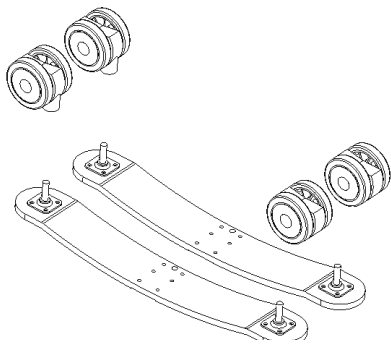
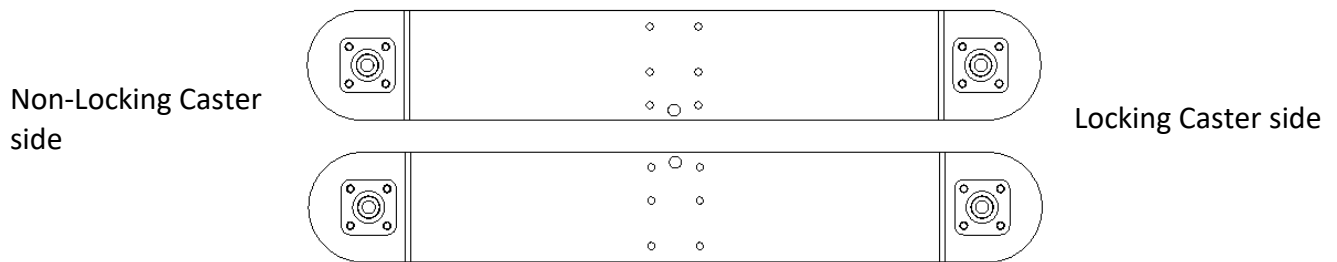

ASSEMBLY of Bases to framed board

1. Lay the X2 panel flat on a table or the floor.
2. Position bases as shown below.
3. Screw base onto frame using the provided hardware.

