



CONTRACT FURNITURE & INTERIORS

2024 CATALOG

CONTENT



- 4** OMBRIA Gradient Glass
- 6** CALYX GLASS Markerboard -
Magnetic, Non-Magnetic, Non-Glare
- 8** PROFILE Porcelain Markerboard
- 10** CURSIVE Wall-Mounted Markerboard
- 12** RAVINA Wall-Mounted Markerboard
- 14** MINA Mobile & Space Creator
- 16** MIX Contemporary Wall-Mounted Board
- 17** MIX Industrial Wall-Mounted Board
- 18** MIX Contemporary Mobile Board
- 20** MIX Industrial Mobile Board
- 22** MIX Biophilic Panel
- 24** SWITCH Wall-Mounted Board
- 26** SWITCH Mobile Board
- 28** VENUE Wall-Mounted Board
- 30** VENUE Mobile Board
- 32** VENUE Space Divider
- 34** RIPPLE Space Divider
- 36** EDIFY Mobile Board
- 38** ACENO Collection
- 40** NIMBUS Multi-Purpose Mobile
- 41** CONCEPT Wall-Mounted Board
- 42** CONNECT X2 Wall-Mounted Board -
Markerboard, Tackboard, Modular System
- 44** CONNECT X2 Mobile Board
- 46** CONNECT X2 Space Creator
- 48** MOTIF Markerboards and Tackboard
- 49** ENVISION Board
- 50** XCHANGE Board
- 51** TRAK-IT Sliding System
- 52** EVOLVE Markerboards and Tackboard
- 53** EVOLVE Sliding System
- 54** Horizontal Sliding Board System
- 55** Tack Wall
- 56** Large Format Glass Marker System
- 57** Large Format Porcelain Marker System
- 58** Accessories
- 60** Ombria Gradient Colors
- 61** Calyx Glass and LCS Porcelain Colors
- 61** Trim Colors
- 62** Calyx Acoustic Colors and Finishes
- 63** Materials

WRITING SURFACES

A dry erase whiteboard's effectiveness as a communication tool is only as good as its writing surface, which is the primary medium for exchanging visual information. Not all writing surfaces are equal, and the quality and composition of the material used to make them directly affect the user experience.

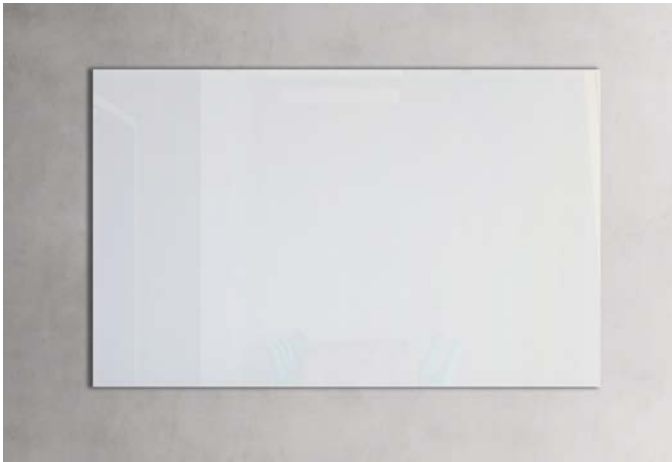

Invisi-Mount Calyx Glass Markerboard

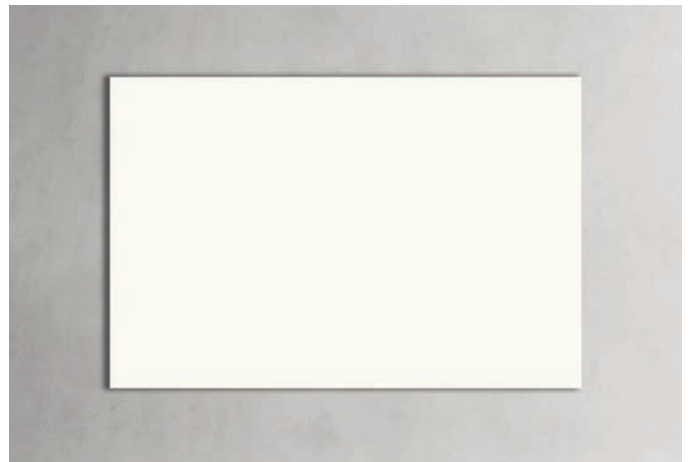

Profile LCS Porcelain Markerboard

CALYX GLASS

- Unlimited Color Options
-
- Customizable Printed Graphics
-
- Erases Well, Easy to Clean
-
- Stylish, Endless Design
-
- Works with Rare Earth Magnets
-
- Non-porous surface makes it naturally bacteria resistant and easily cleanable
-
- SCS Indoor Advantage Gold Certified

LCS PORCELAIN

- White, Light Gray, Beige Color Options
-
- Life of Building Warranty
-
- Projection Friendly
-
- Scratch and Stain Resistant
-
- Works with Magnets
-
- Non-porous surface makes it naturally bacteria resistant and easily cleanable
-
- SCS Indoor Advantage Gold Certified and Cradle-to-Cradle Certified

OMBRIA GLASS-*NEW*

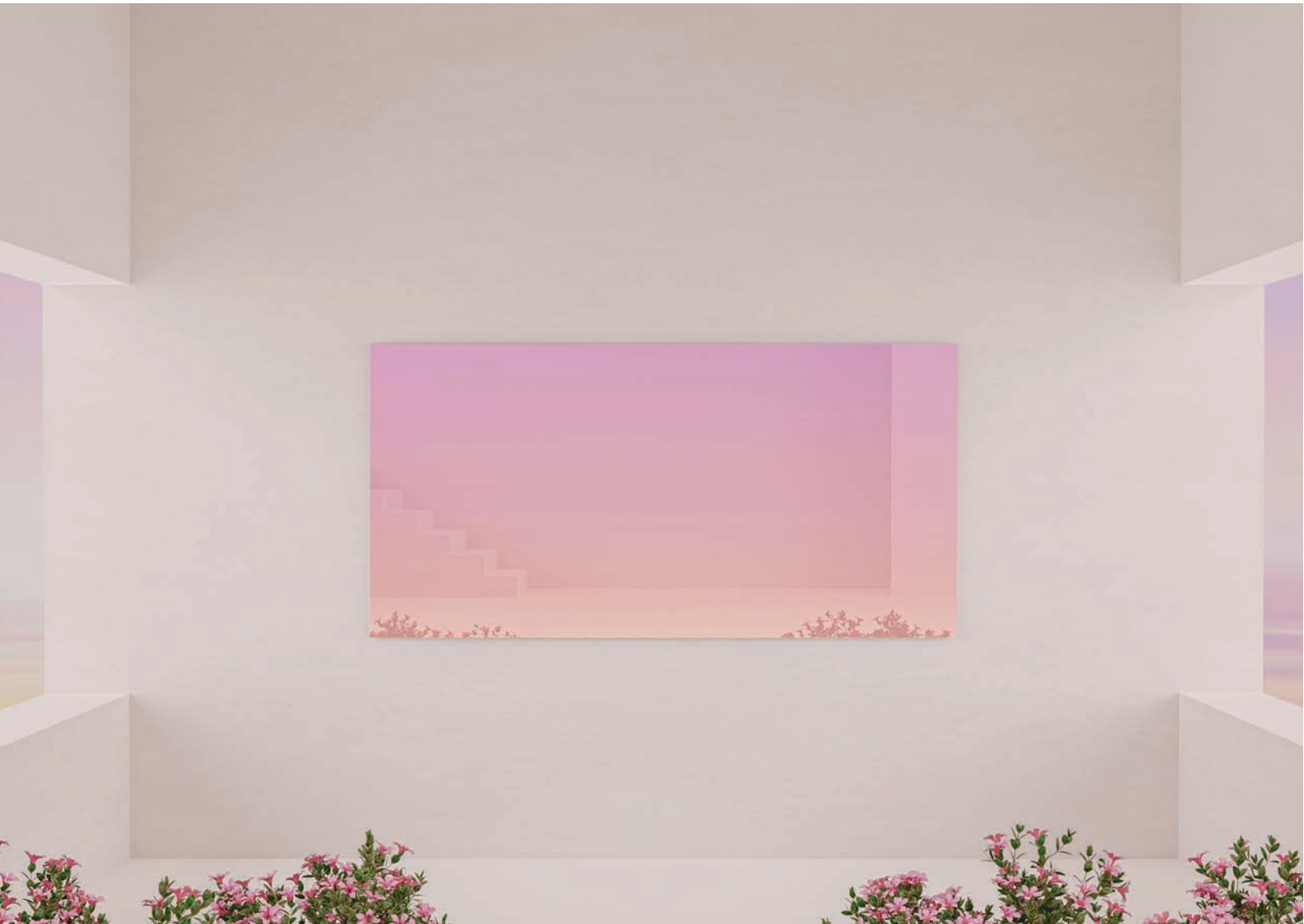

 [View Product Online](#)

A harmonious blend of colors on glass markerboards



**Ombria Glass with transparency do not accept magnetic accessories*

FEATURES

- Choose one, two, or three color gradients to create an art piece that is useful for collaboration
- Choose from 50 standard preset gradient colors or create custom gradients - see page 60 for standard gradient colors
- *Accepts magnetic accessories
- Ombria gradient can be applied to any glass panel – wall-mounted, mobile, or space creator

CALYX GLASS MARKERBOARDS



 [View Product Online](#)

Stylish, functional and easy to maintain glass surface

CALYX GLASS MARKERBOARDS

FEATURES

- Silky smooth surface writes easily, erases cleanly – no ghosting
- 1/4" tempered low-iron, CalyxClear glass
- Select from mounting methods
 - Invisi-mount – no visible hardware; gives the appearance of a floating panel
 - Stand-off Edge or Through Glass Mount – attractive stainless steel finish
- Available in 10 standard colors and over 180 optional powder coat colors - see page 61 for standard glass colors
- Standard sizes range from 2' x 3' up to 5' x 10' & 4' x 12'
- Custom logos, colors and sizes available

OPTIONS

Magnetic

- Steel-backed glass doubles as a "tack" surface
- Includes 4 rare earth magnets

Non-Glare

- Satin, velvety surface provides minimal distractions from glare and reflections



Standoff Through Glass Mount Whiteboard



Edge Mount Glass Whiteboard

Mounting Options

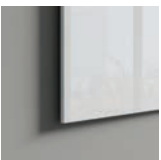

Invisi-Mount



Standoff Edge Mount

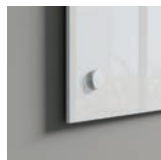

Standoff Through Mount

PROFILE LCS PORCELAIN MARKERBOARDS



 [View Product Online](#)

A cost effective alternative to frameless glass whiteboards

PROFILE LCS PORCELAIN MARKERBOARDS

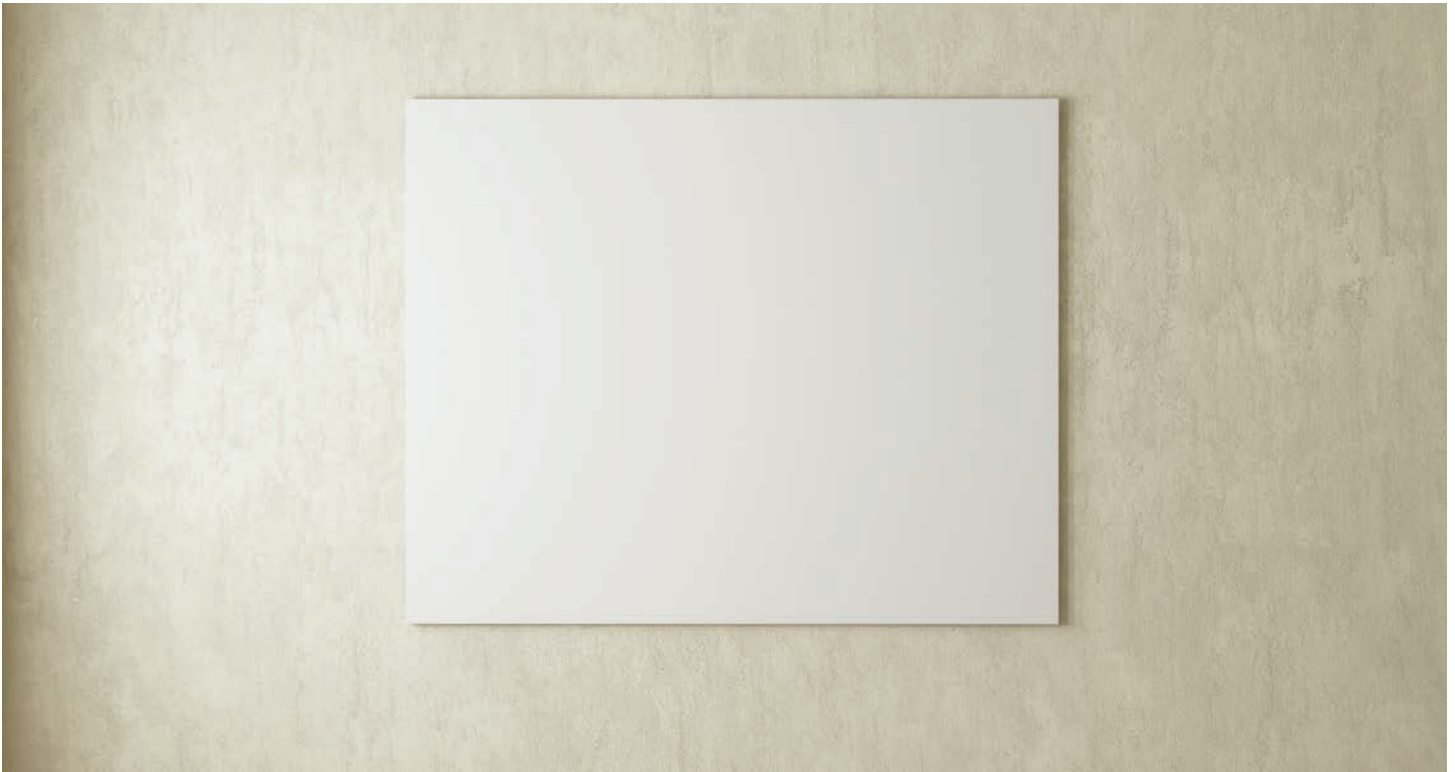

Profile LCS Porcelain Edge Detail

FEATURES

- Projection friendly, smooth writing surface writes easily, erases cleanly – no ghosting
- Available in LCS Porcelain dry erase whiteboard, chalkboard or marker wall- see page 61 for color options
- No visible hardware; gives the appearance of a floating panel
- Accepts magnetic accessories
- Available in sizes up to 5' x 8'
- Lifetime warranty

CURSIVE BOARD



FEATURES

- Combination of our best in class writing surfaces and tack surfaces
- Stylish curved corners
- Writing Surfaces: LCS Porcelain - 6 standard colors or Calyx Glass - 10 standard glass colors - see page 61 for color options
- Calyx Acoustic tackable pads in 5 standard plus 19 additional colors for order - see page 62 for color options
- Maharam tackable fabric in 20 standard colors - see page 63 for color options

STANDARD SIZES (HxW)

36" x 12"

36" x 24"

36" x 48"

48" x 12"

48" x 24"

48" x 48"

48" x 60"

48" x 72"

CURSIVE:ONE BOARD-**NEW**



FEATURES

- Single panel surface with soft rounded corners
- Writing surfaces available in Calyx Glass and LCS Porcelain - accepts magnetic accessories
- Tackable surfaces available in Calyx Acoustic and Maharam fabric

STANDARD SIZES (HxW)

24" x 36"
36" x 48"
48" x 48"
48" x 60"
48" x 72"
48" x 96"

 [View Product Online](#)

Note: LCS Porcelain, Calyx Acoustic, and fabric wrapped boards are 1/2" smaller, and Calyx Glass is 1/4" smaller on all standard sizes.

RAVINA BOARDS-*NEW*



 [View Product Online](#)

Framed writable or tackable wallboard with a stylish reveal



Trim and reveal gap detail

FEATURES

- Stylish 5/16" reveal gap between the trim and the perimeter of the board
- 5/16" face trim and 1" depth
- Writing surfaces available in Calyx Glass and LCS Porcelain - see page 61 for color options
- Ombria gradients on glass available - see page 60 for color options
- Writing surfaces accept magnetic accessories
- Tackable surfaces are fabric wrapped and available in Maharam, Guilford, and Carnegie fabrics - see page 63 for color options
- Trim comes available in responsibly harvested Ash wood or satin anodized aluminum with option to powder coat in 24 standard colors or 180 additional colors
- Ash wood is available in Clear, Vellum, Driftwood, and Rustic stains

STANDARD SIZES (HxW)

- 24" x 36"
- 36" x 48"
- 48" x 48"
- 48" x 60"
- 48" x 72"
- 48" x 96"

MINA MOBILES & SPACE CREATORS-**NEW**



 [View Product Online](#)

Frameless minimalist style mobile and space creator designed for the modern workspace

MINA MOBILES & SPACE CREATORS-**NEW**



Foot Detail

FEATURES

- Panels are double sided with option to choose from both writing or tack surfaces
- Writing surface available in Calyx Glass magnetic or non-magnetic, LCS Porcelain or LCS Chalk - see page 61 for color options
- Ombria gradients on glass available - see page 60 for color options
- Tackable surface available in Calyx Acoustic or designer fabrics in Maharam, Guilford, or Carnegie - see page 63 for color options
- Sturdy steel feet are available in 24 standard gloss or 10 matte colors, 180 optional colors, and unlimited custom colors
- Mobile comes with 2 locking and 2 non-locking casters
- 4 units can nest within a 24.5" footprint depth

STANDARD SIZES

H 60", 72" **W** 36", 42" **D** 21"

MIX | CONTEMPORARY WALL-MOUNTED BOARDS



 [View Product Online](#)



FEATURES

- MIX Contemporary Wall-Mounted Boards are companions to the Contemporary Mobiles
- Available in Calyx Glass and LCS Porcelain writing surfaces or Calyx Cork tack surface
- Metal accent strip highlights the integrated marker rail available in 180 powder coat colors
- Responsibly harvested Ash wood frame available in Clear, Vellum, Driftwood, and Rustic stains - see page 62 for MIX color options

STANDARD SIZES (HxW)

- 3' x 4' 4' x 3'
- 3' x 5' 4' x 4'
- 4' x 6'
- 4' x 8'

MIX | INDUSTRIAL WALL-MOUNTED BOARDS



 [View Product Online](#)



FEATURES

- MIX Industrial Wall-Mounted Boards are companions to the Industrial Mobiles
- Available in Calyx Glass and LCS Porcelain writing surfaces or Calyx Cork tack surface
- Metal accent strip highlights the integrated marker rail available in matte black or 180 optional powder coat colors - see page 62 for MIX color options
- Responsibly harvested Ash wood frame available in Clear, Vellum, Driftwood, and Rustic stains
- Industrial Markerboards come with metal corner accents with exposed hex bolts in matte clear finish

STANDARD SIZES (HxW)

3' x 4' 4' x 3'
3' x 5' 4' x 4'
 4' x 6'
 4' x 8'

MIX | CONTEMPORARY MOBILE BOARDS



 [View Product Online](#)

Choose your expression

MIX | CONTEMPORARY MOBILE BOARDS



FEATURES

- Available in Calyx Glass and LCS Porcelain writing surfaces or Calyx Cork tack surface
- Responsibly harvested Ash wood frame available in Clear, Vellum, Driftwood, and Rustic stains
- Metal bases and accent strips available in Signal White, Slate Grey or Matte Black with 180 optional powder coat colors - see page 62 for MIX color options
- Optional metal shelf to match the base (partial height only)
- Mobiles come with hubless casters

AVAILABLE SIZES (HxW)

Partial Height	Full Height
72" x 36"	72" x 36"
72" x 48"	72" x 42"
72" x 60"	72" x 48"
*72" x 72"	**72" x 60"

**Available for Calyx LCS Porcelain and LCS Porcelain/Cork only*

***Available for Calyx LCS Porcelain only*



 [View Product Online](#)

Customizable components – from Ash wood stains, accent strip and metal base colors to best in class writing surfaces

MIX | INDUSTRIAL MOBILE BOARDS



FEATURES

- Available in Calyx Glass and LCS Porcelain writing surfaces or Calyx Cork tack surface
- Metal accent strip highlights the integrated marker rail available in matte black or 180 optional powder coat colors - see page 62 for MIX color options
- Responsibly harvested Ash wood frame available in Clear, Vellum, Driftwood, and Rustic stains
- Metal bases come with exposed hex bolts in matte clear finish
- Optional metal shelf to match the base (partial height only)
- Industrial casters include exposed brake locks

AVAILABLE SIZES (HxW)

Partial Height	Full Height
72" x 36"	72" x 36"
72" x 48"	72" x 42"
72" x 60"	72" x 48"
*72" x 72"	**72" x 60"

**Available for Calyx LCS Porcelain and LCS Porcelain/Cork only*

***Available for Calyx LCS Porcelain only*

MIX | BIOPHILIC MOBILE BOARDS



 [View Product Online](#)

A creative, long-lasting option for nature-themed interiors

MIX | BIOPHILIC MOBILE BOARDS



Serenity



Om

FEATURES

- Available on Contemporary or Industrial mobiles - see page 62 for MIX color options
- Biophilic panels retain their vibrant, fresh-cut look for 10+ years, giving designers a creative, long-lasting option for nature-themed interiors
- These all natural preserved plants do not require water, sunlight, soil, misting or irrigation
- Choose from two standard designs - Serenity and Om; custom designs available upon request
- Numerous credit contributions for LEED® v4 projects (BD+C, ID+C, O+M)
- Wall garden installations have significant noise reduction coefficient (NRC)
- Conforms to requirements within the WELL Building Standard™ and the Healthy Hospital Initiative (HHI)

AVAILABLE SIZES

Standard size 72" x 42" fits on Contemporary or Industrial full height mobiles. Custom sizes available.

SWITCH WALL-MOUNTED BOARDS



 [View Product Online](#)

The slim trim elements give the board a minimalistic quality

SWITCH WALL-MOUNTED BOARDS



FEATURES

- Switch Boards are designed to be functionally agile; providing a writable surface and optional tackable pads that can be moved and configured for collaborative use
- An integrated marker tray gives a pop of color along the bottom edge of the board
- Writing Surfaces: LCS Porcelain - 6 standard colors or Calyx Glass - 10 standard glass colors - see page 61 for color options
- Frame and marker tray available in 10 standard matte finish colors - see page 61 for color options
- TacPads available in Calyx Acoustic and fabrics in Carnegie, Maharam, and Guilford - see page 62-63 for color options

STANDARD SIZES

H 3', 4' W 4', 5', 6', 8'

SWITCH MOBILES



 [View Product Online](#)

Ideal for multi-use settings, most notably the ability to stack and store mobiles into a small footprint

SWITCH MOBILES



FEATURES

- An integrated marker tray gives a pop of color along the bottom edge of the board while mimicking the shape of the legs as it bends away from the writing surface
- The slim trim elements give the board a minimalistic quality
- Switch is designed to be functionally agile; providing an optional tackable surfaces that can be moved and configured for collaborative use
- Mobile boards can be easily nested and stowed away when not in use
- Comes with two (2) locking and two (2) non-locking Hubless Casters.
- Writing Surfaces: LCS Porcelain - 6 standard colors or Calyx Glass - 10 standard glass colors - see page 61 for color options
- Marker tray, frame and leg available in 10 standard matte finish colors - see page 61 for color options
- TacPads available in Calyx Acoustic and fabrics in Carnegie, Maharam, and Guilford - see page 62-63 for color options

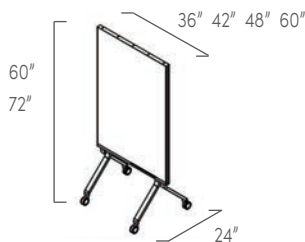

STANDARD SIZES

H 60", 72" W 36", 42", 48", 60" D 24"

VENUE WALL-MOUNTED BOARDS



 [View Product Online](#)

Stylish frame and distinctive angled marker tray enhance a variety of aesthetics

VENUE WALL-MOUNTED BOARDS



FEATURES

- The stylish frame and distinctive angled marker tray available in 10 standard matte finish colors - see page 61 for color options
- Available in 8 standard sizes, custom sizes available
- Writing Surfaces: LCS Porcelain - 6 standard colors or Calyx Glass - 10 standard glass colors - see page 61 for color options

STANDARD SIZES

H 3', 4' **W** 4', 5', 6', 8'

VENUE MOBILES



Venue T-Leg Mobile

Venue V-Leg Mobile

 [View Product Online](#)

Venue's timeless design allows this adaptive visual communications mobile to work with any collaboration space

VENUE MOBILES



Venue V-Leg Mobile



Venue T-Leg Mobile

FEATURES

- **V-Leg Mobile:** upright design with board surface starting approximately 18" from the floor, slightly more approachable; comes with two (2) locking and two (2) non-locking Hubless Casters
- **T-Leg Mobile:** lower profile design with board surface starting approximately 10" from the floor, convenient nesting - available in full or split panels and comes with two (2) locking and two (2) non-locking Hubless Casters
- **T-3 Leg Mobile:** board surface starting approximately 10" from the floor, convenient for tight spaces - comes with two (2) locking and one (1) non-locking Hubless Casters
- **Writing Surfaces:** LCS Porcelain - 6 standard colors or Calyx Glass - 10 standard glass colors - see page 61 for color options
- **Trim available in 10 standard matte finish colors** - see page 61 for color options
- **TacPads available in Calyx Acoustic and fabrics in Carnegie, Maharam, and Guilford** - see page 62-63 for color options

STANDARD SIZES

H 60", 72" **W** 36", 42", 48", 60" **D** 24"

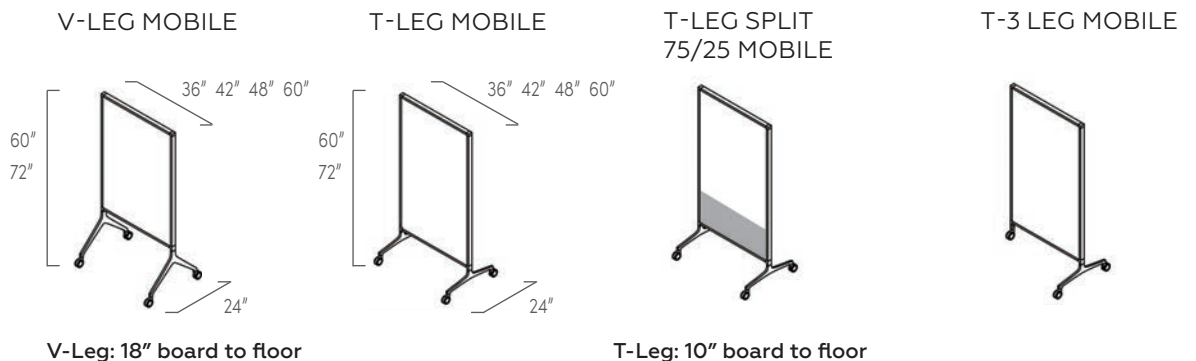

VENUE SPACE DIVIDERS



 [View Product Online](#)

Freestanding space divider panels provide privacy and room segmentation

VENUE SPACE DIVIDERS

FEATURES

- Flexible and adaptive room dividers provide a visual border to define space not only within the open environment but within systems themselves
- Create a boundary of space to define areas of collaboration and areas of concentration
- Divide personal space between benching seats and workstation clusters/packs
- Integrated textiles and perforated acoustic panels add another layer of privacy beyond the visual
- Split panels combine writable and tackable fabric surfaces in 25/75, 75/25, and 50/50 split options
- Writing Surfaces – LCS Porcelain - 6 standard colors or Calyx Glass - 10 standard glass colors - see page 61 for color options
- Tackable Surfaces – Carnegie, Maharam, or Guilford materials available - see page 63 for color options
- Trim available in 10 standard matte finish colors - see page 61 for color options

STANDARD SIZES

H 48", 60", 72" W 36", 48" D 15"

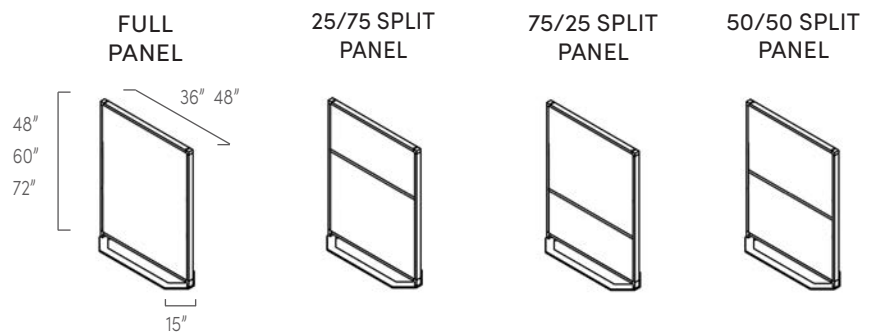

RIPPLE SPACE DIVIDERS



 [View Product Online](#)

Divider screens with a design element

RIPPLE SPACE DIVIDERS

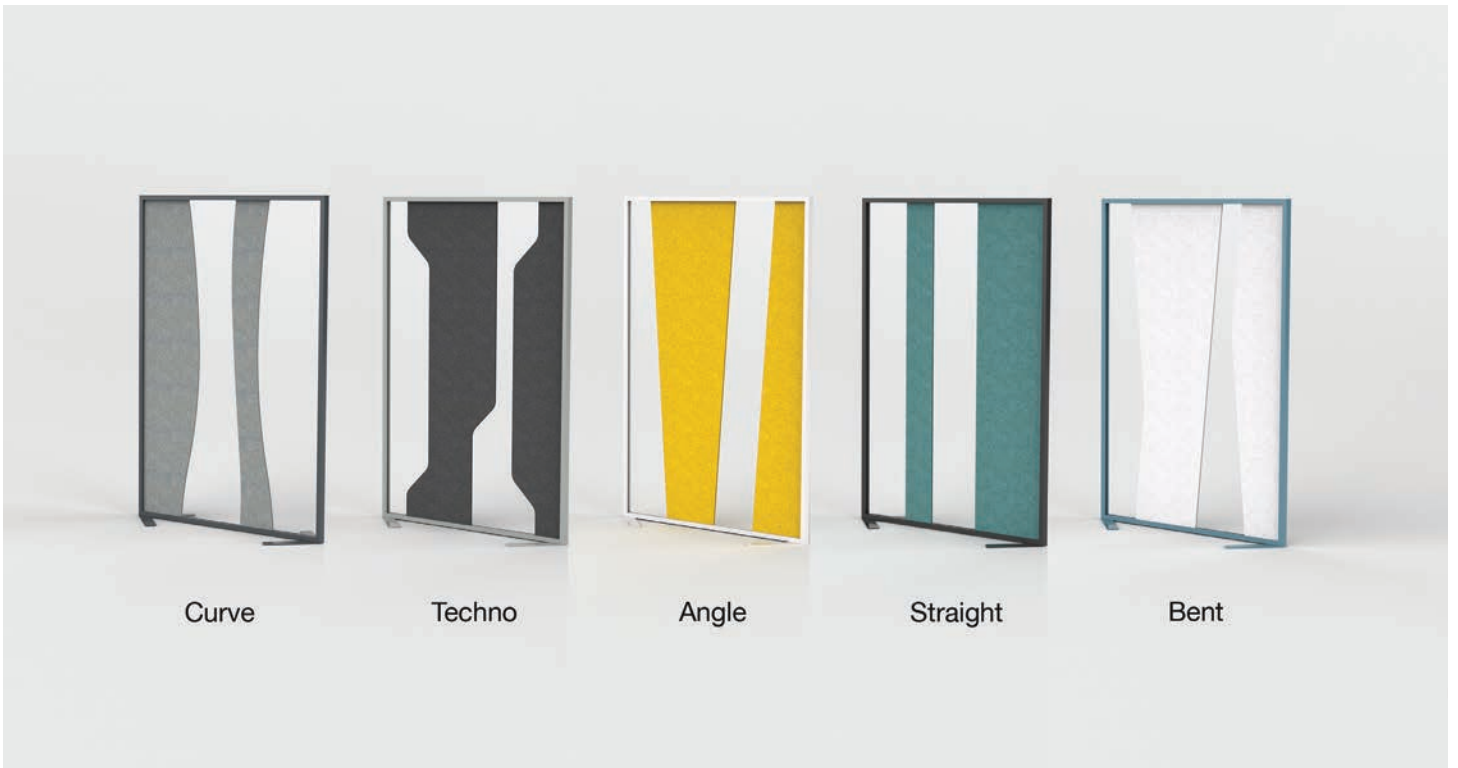

STANDARD SIZES

Size (HxW)	Panels
60" x 36"	4
60" x 42"	4
60" x 48"	4
60" x 60"	5
72" x 36"	4
72" x 42"	4
72" x 48"	4
72" x 60"	5

FEATURES

- A design-oriented space divider that is handcrafted with both acoustic and acrylic surfaces
- Low profile trim, to the floor privacy, and the space-saving versatility of the boomerang foot
- Ripple separates and defines spaces while keeping an open feel
- Frame & base color comes in satin anodized trim or choose from 10 optional matte powder coat finishes - see page 61 for color options
- Acoustic Panel is available in 5 standard plus 19 additional colors for order - see page 62 for color options

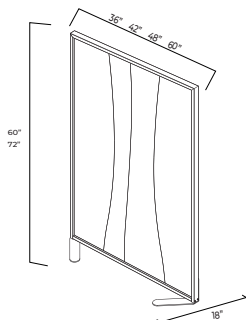

EDIFY MOBILE



 [View Product Online](#)

Tools within reach to enlighten and engage with your audience

EDIFY MOBILE

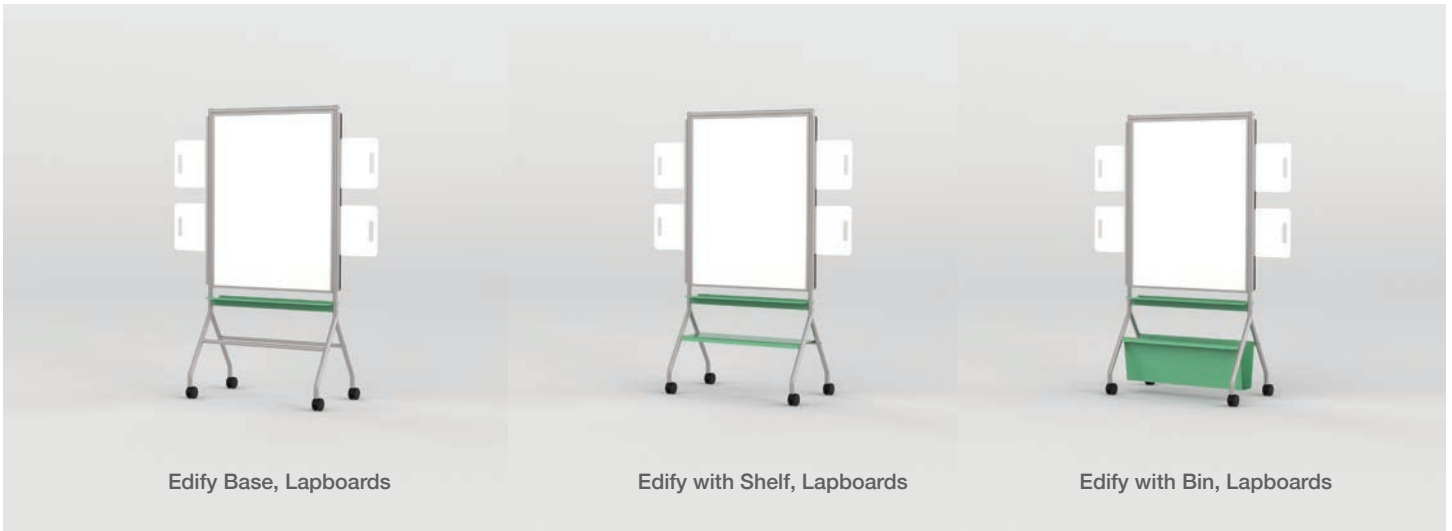

Edify Base, Lapboards

Edify with Shelf, Lapboards

Edify with Bin, Lapboards



FEATURES

- Sturdy steel frame with tray, optional bin or shelf available in vibrant color options
- LCS (Lifetime Ceramic Surface) Porcelain writing surface
- Standard height is 72" from the floor
- Frame, tray, bin, and shelf available in 5 suggested standard color options - choose 1 or 2 colors - see page 61 for color options
- Comes with two locking and two non-locking casters

STANDARD SIZES

H 72" W 36", 48" D 21 -1/4"

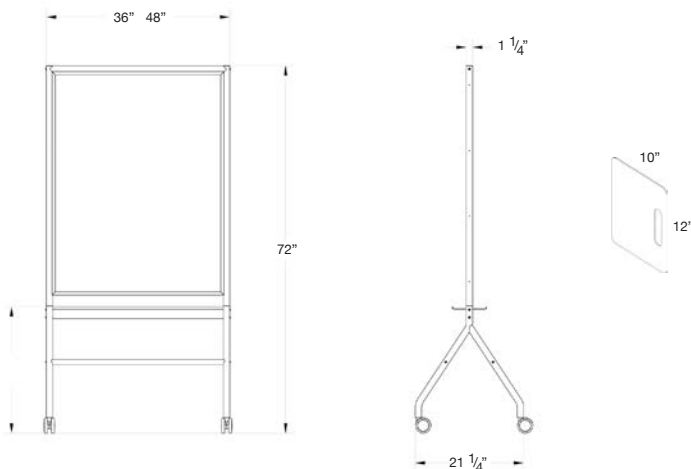

ACENO COLLECTION



 [View Product Online](#)

Flexible solution for today's collaborative workspaces.
Lightweight panels easily move from the wall track system, to a
stylish room divider, to a beautiful cart.

ACENO COLLECTION

FEATURES

Room Divider

- Stylish, steady base in standard or custom colors
- CIS writing surface with Calyx Acoustic reveal on both sides
- CIS writing surface comes in standard white with additional 4 colors to choose from
- Panel core is available in Calyx Acoustic - 5 standard plus 19 additional colors for order - see page 62 for color options

Track Wall System

- Wall track system available with optional back panel in Calyx Glass or LCS porcelain; no back panel required for functionality
- Track is available in 10 standard matte finish colors - see page 61 for color options

Storage Cart

- Panels placed on each side for use as a mobile markerboard
- Cart can store up to 8 panels
- Solid wood frame
- Comes with two locking and two non-locking casters
- Circular cutout handles for ease of mobility

PANEL SIZES (HxW)

- 48" x 28"
- 48" x 36"
- 55" x 28"
- 55" x 36"
- 68" x 28"
- 68" x 36"

TRACK SYSTEM - WIDTH SIZES

- 48", 72", 96"

CART SIZE (HxWxD)

- 45" x 40" x 21"



Aceno Wall Track System



Aceno Storage Cart

OPTIONAL CIS COLORS



Gray Green Blue Orange

NIMBUS MULTI-PURPOSE MOBILE



 [View Product Online](#)

FEATURES

- Beautiful solution for room division
- Side panels fitted with LCS Porcelain writing surface, acoustic, tack surface, or a combination of surfaces
- Center shelves accessible from both sides
- Cord management access on back of shelves
- Solid wood frame
- Comes with two locking and two non-locking casters

SIZE (HxWxD)

60" x 40" x 19"

CONCEPT WALL-MOUNTED BOARDS



 [View Product Online](#)



Tackboard - [View HERE](#)



Marker Tray (standard)

FEATURES

- 5/16" aluminum trim profile with eased edge - available with marker or tack board
- For longer lengths, ask about Concept Connected; boards are joined on site with a narrow H-bar or spline
- Whiteboards – Projection friendly Low Gloss White LCS Porcelain enamel steel
- Tackboards – Carnegie, Guilford or Maharam fabrics, Calyx Cork or COM
- Aluminum frame in satin anodize finish comes with or without full length marker tray

STANDARD SIZES (HxW):

2' x 3'	4' x 4'	5' x 6'
3' x 4'	4' x 5'	5' x 8'
	4' x 6'	5' x 10'
	4' x 8'	5' x 12'
	4' x 10'	
	4' x 12'	



X2 Markerboard

 [View Product Online](#)

The slim trim elements give the board a minimalistic quality

CONNECT X2 TACKBOARDS & MODULAR BOARDS

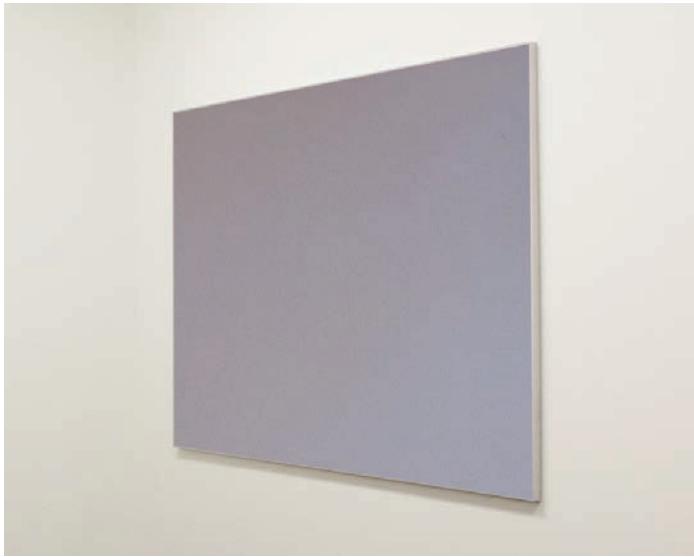

X2 Tackboard

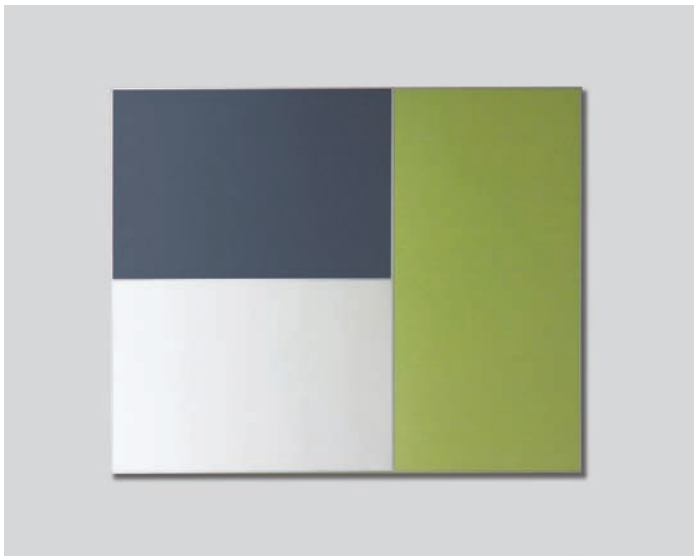

X2 Modular System

FEATURES

- Narrow 1/4" satin anodized aluminum trim profile with eased edge
- Available in Calyx Glass or LCS Porcelain markerboard, tackboard or modular system – combining writing and tack surface in multiple groups and unlimited configurations
- Satin anodized trim can be powder coated in 24 standard colors, 180 optional colors, and unlimited custom colors - see page 61 for color options
- Available with optional fixed marker tray or magnetic tray
- Trim available with or without reveal
- Tackboard surfaces available in Calyx Cork, Guilford, Carnegie, Maharam or pre-approved COM fabrics - see page 63 for color options

STANDARD SIZES (HxW):

1.5' x 2'	4' x 4'
2' x 3'	4' x 6'
3' x 4'	4' x 8'

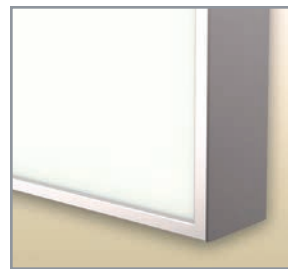

No reveal



With reveal

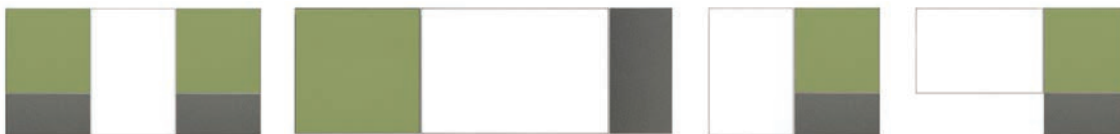

Sample configurations

CONNECT  X2 MOBILE BOARDS



 [View Product Online](#)

Easy to move with flexible display and presentation solutions while preserving floor and work space



FEATURES

- Available with any combination of markerboard or tackboard
- Mobiles are 72" high
- Calyx Glass and LCS Porcelain mobiles available in widths 30", 36", 42", 48", and 60" for full height (A) only
- Markerboard/Tackboard combination (B); Partial height (C); and 3 caster mobiles (D) available in two widths: 36" and 48"
- Full height, open or tackable panel at the bottom
- Locking casters
- Optional ganging mechanism
- Custom sizes available



A. Full height mobile markerboard in Calyx Glass or LCS Porcelain (X2-MM)
 B. Combination mobile - top panel in Calyx Glass or LCS Porcelain; and bottom tack panel (X2-MMNT)
 C. Partial height mobile (X2-MMN); not available with glass writing surface
 D. 3-Caster mobile (X2-MM3); not available with glass writing surface



 [View Product Online](#)

A functional, movable environment that can be reconfigured for privacy and individual needs



Customize panel size, material and color.
Panels can be markerboard, tackboard or combination of both.

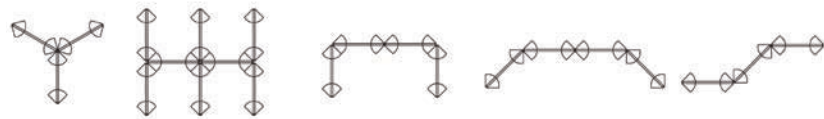

Unlimited configurations

FEATURES

- Stand alone or group together; simple ganging mechanism included
- Select from one to four tiles
- Panels extend fully to the floor for complete privacy
- Low profile foot provides stability
- Markerboard in LCS Porcelain
- Tackboards in Calyx Cork, Guilford, Carnegie, Maharam or approved COM fabrics - see page 63 for color options

STANDARD SIZES (HxW):

- 72" x 30"
- 72" x 36"
- 72" x 48"

MOTIF WALL-MOUNTED BOARDS



 [View Product Online](#)



Wood Trim



Tackboard Surface

FEATURES

- Rounded edge profile with a narrow face trim - available with marker or tack board
- Whiteboards – Projection friendly Low Gloss White LCS Porcelain enamel steel
- Tackboards – Carnegie, Guilford or Maharam Fabrics, Calyx Cork or COM
- Custom finishes available

STANDARD SIZES (HxW):

- 2' x 3'
- 3' x 4'
- 4' x 4'
- 4' x 6'
- 4' x 8'

ENVISION GRAPHIC BOARDS

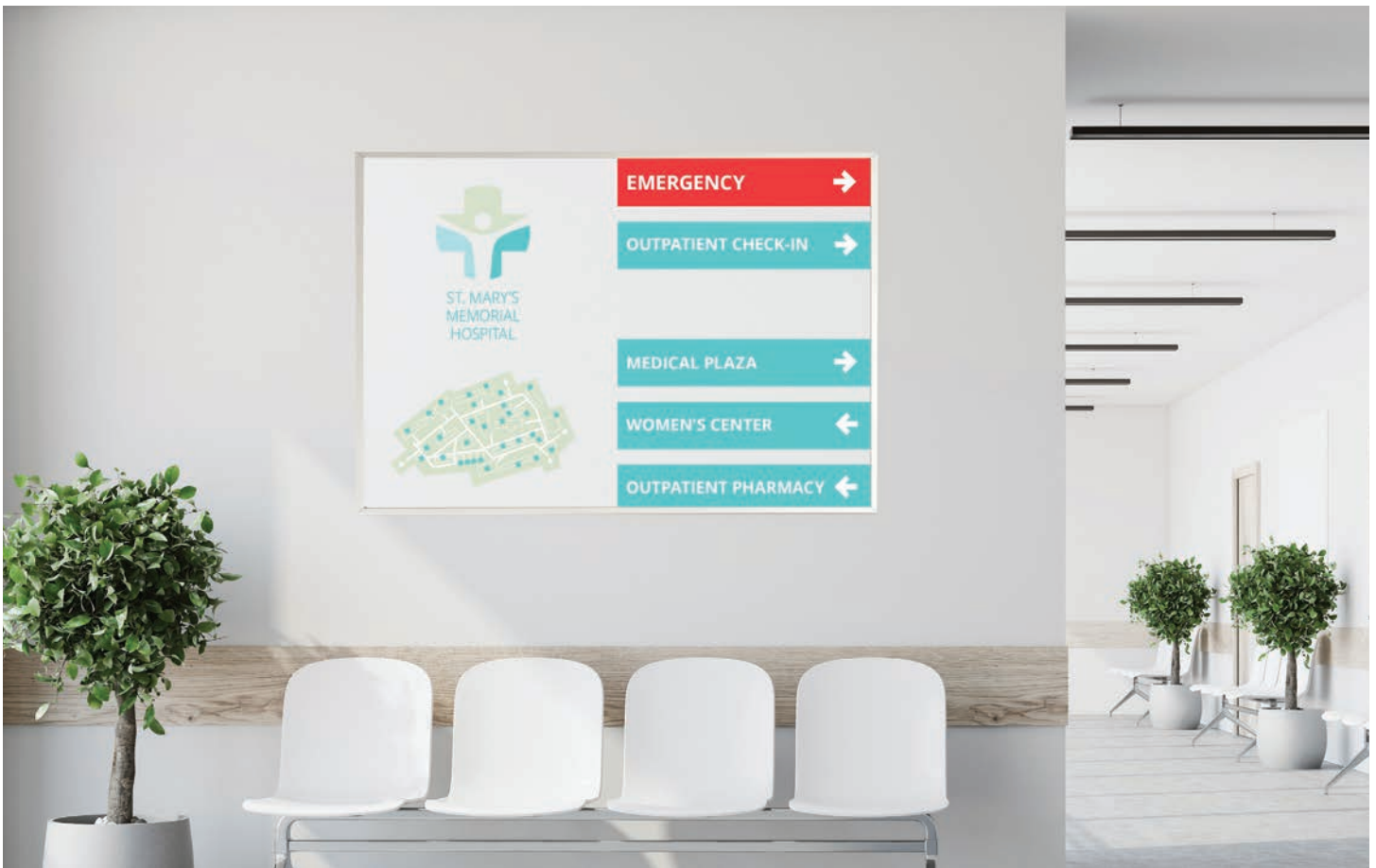

 [View Product Online](#)



FEATURES

- Dry-erase whiteboard surface with digitally printed graphics – photo quality images, logos, etc.
- Envision it: patient room boards, calendars, planners, performance tracking
- 3/8" aluminum frame comes standard in satin anodized finish, or choose from 180 optional powder coat colors
- Wood frames available in standard wood finishes or custom finishes

STANDARD SIZES (HxW):

- 1.5' x 2'
- 2' x 3'
- 3' x 4'
- 4' x 4'
- 4' x 6'
- 4' x 8'

XCHANGE GRAPHIC BOARDS



 [View Product Online](#)



FEATURES

- Exchange scene, season or message by sliding custom graphic behind clear low-iron tempered glass surface
- Low profile aluminum trim top and bottom
- Built-in marker rail at top
- Standard black or white powder coat finish

STANDARD SIZES (HxW):

- 1.5' x 2'
- 2' x 3'
- 3' x 4'

TRAK-IT SLIDING SYSTEMS



 [View Product Online](#)



FEATURES

- Double-sided panels multiply communication space
- Panels, available in sizes up to 3' x 4', hang landscape or portrait
- Boards can be positioned anywhere along track
- Trak-It Aluminum Rail comes in 10' lengths
- Easy to rearrange – swing out, lift up
- Available in LCS Porcelain markerboard or tackboard surface
- Magnetic marker tray optional

STANDARD SIZES (HxW)

2' x 3'

3' x 4'

EVOLVE WALL-MOUNTED BOARDS



 [View Product Online](#)



Accessory Tray

FEATURES

- LCS Porcelain enamel steel writing surface in projection-friendly low gloss white
- Tackboards available in Guilford, Carnegie, Maharam, Calyx Cork or COM - see page 63 for color options
- Whiteboards available in 2', 3', and 4' heights, in widths up to 12'
- Wide face trim at top and bottom is 2 3/8"; narrow trim on the sides is 5/16"
- Snap-on tray can be easily added or removed

STANDARD SIZES

2' x 3'	4' x 4'	4' x 8'
3' x 4'	4' x 5'	4' x 10'
	4' x 6'	4' x 12'

EVOLVE SLIDING SYSTEMS



 [View Product Online](#)



Snap-on Tray



Sliding Panel

FEATURES

- Sliding board can be added to a fixed wallboard to increase usable surfaces or to conceal/reveal information written on the board surface.
- Fixed whiteboard panel in sizes up to 4' x 8' and sliding panels in 3' and 4' widths
- Sliding panel moves smoothly on top and bottom rollers
- Snap-on tray furnished with sliding panel

STANDARD SIZES (HxW)

Fixed Markerboard:

4' x 4' 4' x 8'
4' x 5' 4' x 10'
4' x 6' 4' x 12'

Sliding Panel:

4' x 3'
4' x 4'

HORIZONTAL SLIDING BOARD SYSTEMS



 [View Product Online](#)

Custom-built to meet your needs, providing optimum display surfaces within easy reach

FEATURES

- Sliding panels are top-suspended and glide easily over aluminum track on molded nylon roller
- Fixed back panels with 2, 3, or 4 sliding panels on 2, 3, or 4 tracks
- Sliding panels and back panels available in LCS Porcelain markerboard, chalkboard, or Calyx Glass writing surfaces
- Tackboard surfaces available in Calyx Cork or Guilford, Carnegie and Maharam fabrics - see page 63 for color options
- Writing surfaces double as magnetic surface
- Resists humidity and fading
- Heavy-duty aluminum housing, trim and panel edging are extruded aluminum with satin anodized finish

TACK WALLS



 [View Product Online](#)

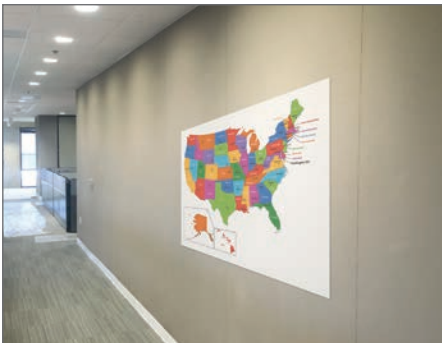

FEATURES

- Cover an entire wall, floor to ceiling up to 10'
- Ideal for offices, board rooms, conference rooms, etc.
- Choose from Guilford, Carnegie and Maharam fabrics; Calyx Cork, custom colors or COM fabrics - see page 63 for color options

CALYX LARGE FORMAT GLASS MARKER SYSTEMS



 [View Product Online](#)



FEATURES

- A large format magnetic glass system ideal for non-stop brainstorming and client presentations
- Low-iron tempered glass for exceptional clarity
- 10 standard colors; 180 optional colors, or custom match colors
- Panel heights up to 10' and widths up to 4'
- Narrow 1/4" satin anodized aluminum trim top and bottom
- Sizes beyond standard range require custom quote and installation services

CALYX LARGE FORMAT PORCELAIN MARKER SYSTEMS





 [View Product Online](#)









FEATURES

- A magnetic large format system for walls configured for your environment
- Projection friendly writing surface that won't ghost or stain
- Panel heights up to 10' and widths up to 4'
- 3/4" to 1-1/4" face perimeter trim in clear satin anodized finish
- Sizes beyond standard range require custom quote and installation services

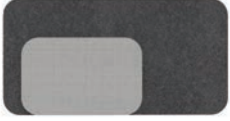
ACCESSORIES

ITEMS	PRODUCT CODE	SIZE	DESCRIPTION
Rare Earth Magnets			
	MGM-REMSQ -B, -W, -G	1.29"h x 1.29"w	.44" thick, rounded corners, available in black, gray or white
Slim Marker Caddy			
	M-MC2 M-MC2P	1 3/8"h, 9"w, 1 3/8"d	Lightweight satin anodized aluminum, holds 4 markers with 3/4" diameter Optional powder coat color available
Stadium Marker Caddy			
	MGM-MC1-S MGM-MC1-M MGM-MC1-L	3 1/2"h, 3 1/8"w, 1 3/4"d 4"h, 4 1/2"w, 2 1/5"d 4"h, 8 1/2"w, 2 2/5"d	Small plastic magnetic holder - up to 8 markers Medium magnetic holder - up to 14 markers Large magnetic holder with divider for up to 14 markers, cleaners and erasers
Magnetic Marker Tray			
	MGM-T1	1 1/2"h, 12"w, 3"d	Satin anodized aluminum tray with rare earth magnets for glass surface Fabric backed tray with eased corners
Slim Magnetic Marker Tray			
	267M1 267MG1 267MG1-P	1 1/2"h, 12"w, 2 1/2"d 1 1/2"h, 12"w, 2 1/2"d 1 1/2"h, 12"w, 2 1/2"d	Slim satin anodized aluminum, magnetic for porcelain surface Magnetic tray with rare earth magnets for glass surface Optional powder coat color available
Magnetic Aluminum Tray			
	264M1 264MP1	2 7/16"h, 12"w, 2 11/16"d 2 7/16"h, 12"w, 2 11/16"d	Satin anodized aluminum, magnetic for porcelain surface Optional powder coat color available
Adhesive Backed Marker Tray			
	GM-Tray-1	2 7/16"h, 12"w, 2 11/16"d	Satin anodized aluminum tray stays in place with double-sided tape and holds in one permanent location
Magnetic Aluminum Accessory Tray			
	AT-12-ALUM AT-12-ALUM-PC	12"w 12"w	Includes 2 extra strong magnets. For use on porcelain surface. Optional powder coat color available.
Magnetic Wood Accessory Tray			
	AT-12-WOOD	12"w	Includes 2 extra strong magnets. For use on porcelain surface.

ACCESSORIES

ITEMS	PRODUCT CODE	SIZE	DESCRIPTION
TacPad 	GS-TP-1409	14" x 9" x .13"	Tackable surface in fabric or acoustic material with rounded corners.
	GS-TP-2714	27" x 14" x .13"	Rare earth magnetic backing. Available in 2 sizes.
	GS-TP-1409-EW	14" x 9" x .13"	Fabric wrapped
	GS-TP-2714-EW	27" x 14" x .13"	Fabric wrapped
Dry-Erase Markers 	LCS673-4	6.5" x .75" diameter	4 broad-tipped markers. One each: red, blue, green and black
	LCS668-4		4 broad-tipped markers and one microfiber cloth
Dry-Erase Cloth 	ECM227E	12" x 12"	Microfiber eraser cloth. Erases evenly with no smearing.
	ECM227D		1 dozen microfiber eraser cloths
Magnetic Eraser 	MGM-ME1	2 1/8"h, 4 1/2"w, 7/8"d	Black felt eraser with strong rare earth magnets
Markerboard Cleaner 	LCS683	8 oz.	Cleans and restores markerboard surfaces
ACCESSORY FOR FURNITURE SYSTEMS			
Partition Panel Clip 	80	2"	Two each spring steel clips to fit over the top of any 2" thick partitions. Small prongs fit underneath the board trim.
	80-3	3"	Two each spring steel clips to fit over the top of any 3" thick partitions. Small prongs fit underneath the board trim.

OMBRIA COLORS

Standard Gradient Colors



Optional Gradient Colors

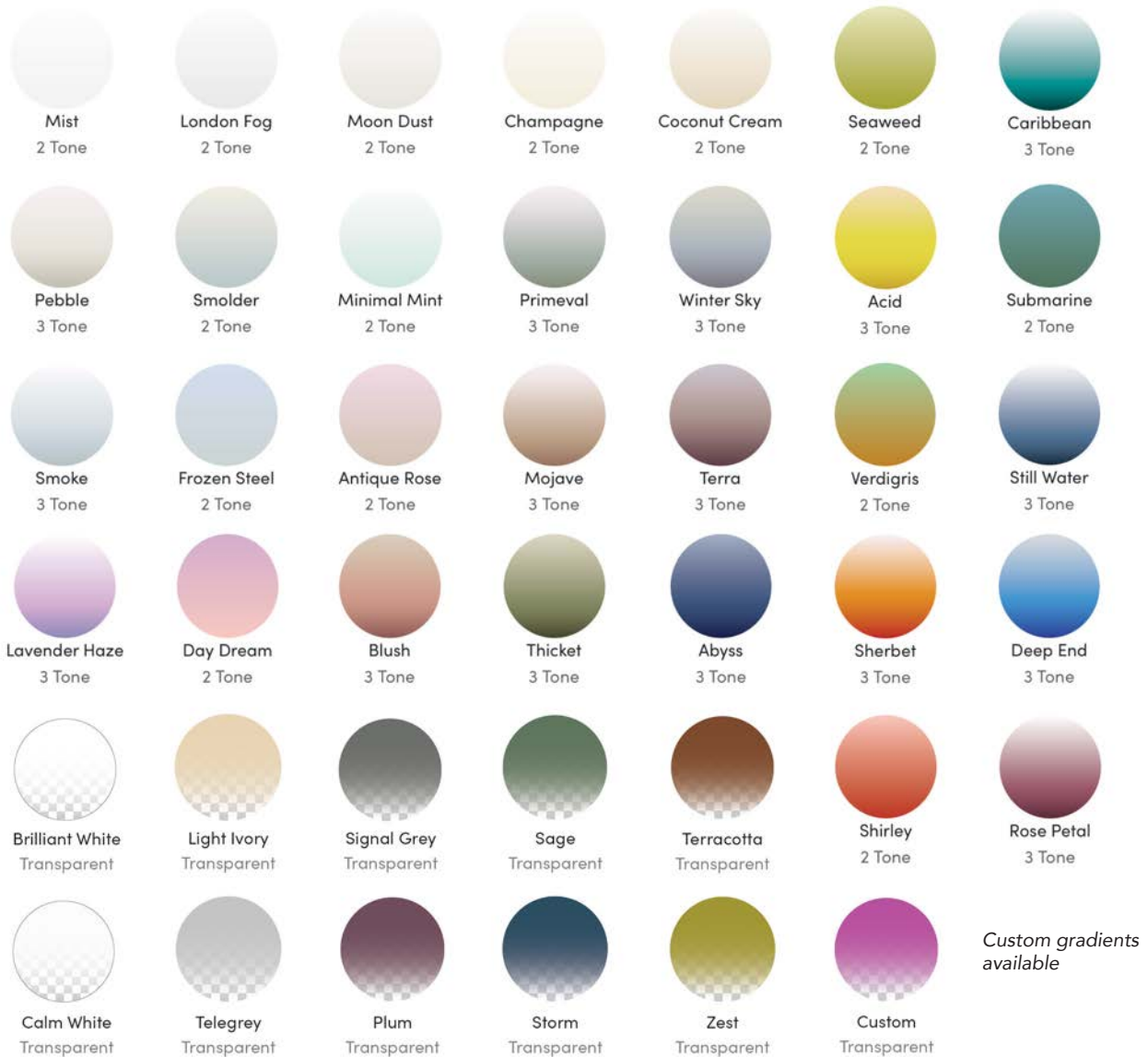

COLORS

Standard Glass Colors



*Brilliant White Telegrey 4 Signal Grey Sage Storm



Calm White Light Ivory Zest Plum Terracotta

* Standard glass color comes in Brilliant White.
Available in 180 optional colors and unlimited custom colors.

LCS Porcelain Colors



White No. 100 Beige No. 102 Light Gray No. 101

LCS Chalkboard Colors



Green Black Gray

Standard Aluminum Trim Color Options



Oyster White RAL1013 Signal Yellow RAL1003 Traffic Orange RAL2009 Red Lilac RAL4001 Signal Blue RAL5005 Moss Green RAL6005 Chocolate Brown RAL8017 Silver Grey RAL7001



Light Ivory RAL1015 Zinc Yellow RAL1018 Ruby Red RAL3003 Claret Violet RAL4004 Cobalt Blue RAL5013 Traffic Green RAL6024 Pale Brown RAL8025 Slate Grey RAL7015



Traffic Red RAL3020 Strawberry Red RAL3018 Ultramarine Blue RAL5002 Violet Blue RAL5000 Sky Blue RAL5015 Leaf Green RAL6002 Signal White RAL9003 Jet Black RAL9005

Also available in over 180 optional powder coat colors

Standard Matte Finish Trim Colors



Grey Slate Grey Turquoise Beige Red Blue



White Black Silver *Bronze *Silver Grey

*Metallic matte finish

Edify Trim Colors



Snow Whisper Mint



Daffodil Royal Crimson

ACOUSTIC COLORS • FINISHES

Calyx Acoustic Color Options

Standard Colors (in stock)

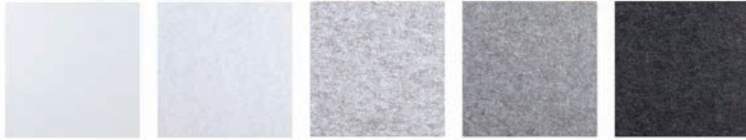

Pearl White Marble Steel Graphite

Additional Colors (for order)



Moondust Bluestone Topaz Sapphire Myrtle Pear Daisy Orange Ruby



Pewter Tiger Eye Camel Quartz Ocean Mist Black Deep Sea Cayenne Moss Stone

MIX Options

MIX Contemporary Base, Accent Strip & Shelf



Signal White RAL9003
Slate Grey RAL7015
Matte Black 302P

MIX Industrial Base & Shelf MIX Industrial Accent Strip

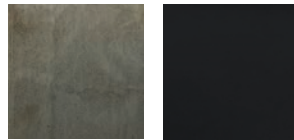

Matte Clear
Matte Black 302P

MIX Wood Finish Options



Clear Vellum Driftwood Rustic

Wood Finish Options



Maple Mahogany Cherry Walnut Espresso Ebony

Custom wood finishes optional

MATERIALS

Fabric Options

Guilford Bailey



Baxter Beige GB011 Belmont Silver GB010 Khaki GB012 Sherman Pewter GB024

Guilford Anchorage

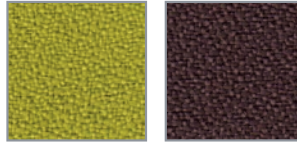

Green Apple GA087 Fossil GA093

Maharam Merit

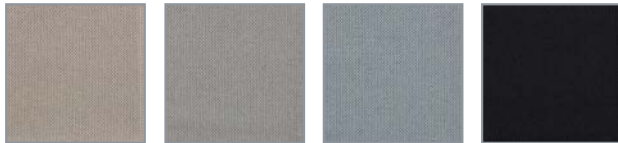

Lynx 028 Overcast 043 Rainfall 009 Blackout 004

Maharam Meld



Seashell 012 Blonde 027 Crater 014 Knight 004

Maharam Manner



Citronella 045 Cottage 023 Dill 043 Nuance 006 Flint 004 Smoky 031 Porpoise 003 Magnetic 032

Maharam Manner



Southwest 047 Kimono 051 Oceanside 040 Valiant 052

Carnegie Nexus

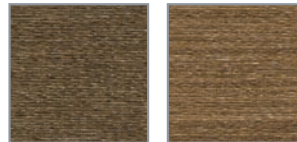

Dune CN912 Oatmeal CN908

Carnegie Quarry



Stone Manor CQ99

Calyx Cork Options

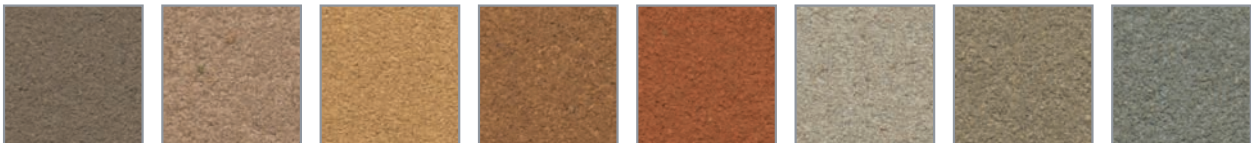

Mushroom 1108 Buff 1109 Fawn 1110 Tan 1100 Cinnamon 1104 Oyster 1103 Smoke 1111 Steel Gray 1113



Graphite 1136 Black 1132 Salsa 1117 Tangerine 1118 Pineapple 1119 Lettuce 1120 Blueberry 1129

Colors are produced with reasonable accuracy.

calyxTM by Claridge

800.434.4610
calyxbyclaridge.com

January 2024